

Product Datasheet

description: OH 60L BLU 2.5kg UN8631 STD 2x18/Pail
product group: Open Top EU
Mauser product no.: uk02160100
customer item no.:

year: 2013
last revision: 2021-02-11
print date: 2022-02-17
page: 1/2

DIMENSIONS

A:	615.00 mm / +/- 5
B:	174.00 mm / + 5
C:	398.00 mm / +/- 3
D:	338.00 mm / +/- 3
E:	370.00 mm

MATERIAL

plastic (body)a:	2.50 kg
plastic tolerance (+/-):	+ 5 %
plastic total:	3.00 kg
steel:	0.30 kg

VOLUME

Volume:	60 L
brimful volume:	63 L / 17 GAL

DRAWING NUMBER

Mauser drawing no.: ./.

LABELING

Embossing/Label/Printing: ./.

label:

customer spec no.:

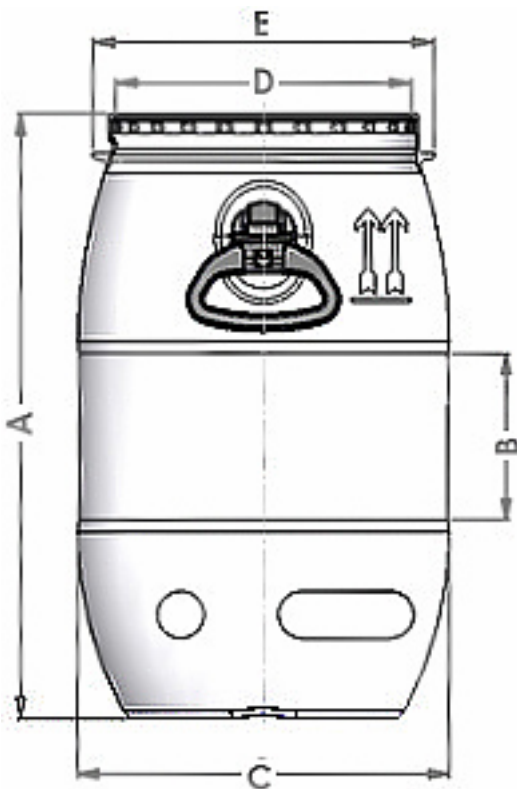

Drawing only exemplary

Kingfisher Direct Ltd
Randall Park Way
Hallcroft
Retford
Nottinghamshire
DN22 7WF

01777 858009 | info@kingfisherdirect.co.uk

Product Datasheet

description:	OH 60L BLU 2.5kg UN8631 STD 2x18/Pall	year:	2013
product group:	Open Top EU	last revision:	2021-02-11
Mauser product no.:	uk02160100	print date:	2022-02-17
		page:	2/2

MODEL / COMPONENTS / ACCESSORIES

Design:	O-Top	Quality:	standard
Color Drum Body:	blue	Color Variations:	./.
Snap-On-Handle/Integrated Handle:	Snap-On-Handle	Lid Gasket and Accessories:	PUR + vent.-pin
Lid Color:	black	clamping ring:	1061-02
Specialties:	./.	De-/Gassing 1:	./.
Quality:	standard	Bung Closure 2a:	./.
Bung Closure 1a:	./.	Bung Closure 2b:	./.
Bung Closure 1b:	./.	Seal Cap 2:	./.
Seal Cap 1:	./.	Assembly Bung Closure 2:	./.
Assembly Bung Closure 1:	./.	Assembly Seal Cap 2:	./.
Assembly Seal Cap 1:	./.		

SHIPPING UNIT

Pallet Type:	customer specific	Pallet Material:	Wood, HT
pieces per pallet:	36	Load Secure:	PE-bag
Bung Orientation on Pallet:	./.		

PACKAGING GROUP

Packaging Group:	X	max. Density (Approval):	1,4 g/cm3
Hydraulic Pressure:	0 (only approved for solids)		

STANDARD FILLING PRODUCTS

	max. vapour pressure at 50C	max. vapour pressure at 55C	density PG I	density PG II	density PG III
solid:	./.	./.	1.4	1.4	1.4
water:	./.	./.	./.	./.	./.
acetic acid:	./.	./.	./.	./.	./.
wetting solution:	./.	./.	./.	./.	./.
white spirit:	./.	./.	./.	./.	./.
n-butyl acetate:	./.	./.	./.	./.	./.
nitric acid 55%:	./.	./.	./.	./.	./.
approval:	UN1H2/X88/S/./D/BAM8631-..				
material type:	HDPE				